

Learn how to have a safer, more accessible environment.

## REMODELED STEPLESS ENTRY

Covered entrance helps control water at low threshold and provides protection during inclement weather

Provide adequate maneuvering space around screen or storm doors

5' x 5' minimum level landing area for maneuvering

Additional lowered peep-hole for seated or short adults and children

Both entry and screen door provide a min. 32" clear opening – lever handle hardware

Provide good overall lighting plus focused lighting at locksets and house number for nighttime security and ease-of-use

High contrast house numbers, easy to read from a distance

Handrail with integral package shelf

Flush or low profile threshold, 1/2" high max.

New porch landing set at same level as interior house floor, eliminates step at entry door

Original small stoop removed

4'-0" wide walkway sloped at 1:20 or less, slopes steeper than 1:20 necessitate handrails

Using a combination of earth berm and retaining walls is an effective method for providing a stepless route to the landing while maintaining an integrated appearance with the home and surrounding site.

18" minimum to pull side of door, 24" preferred

5' x 5' clear level area for maneuvering on the landing is recommended and may be necessary when screen or storm doors are provided.

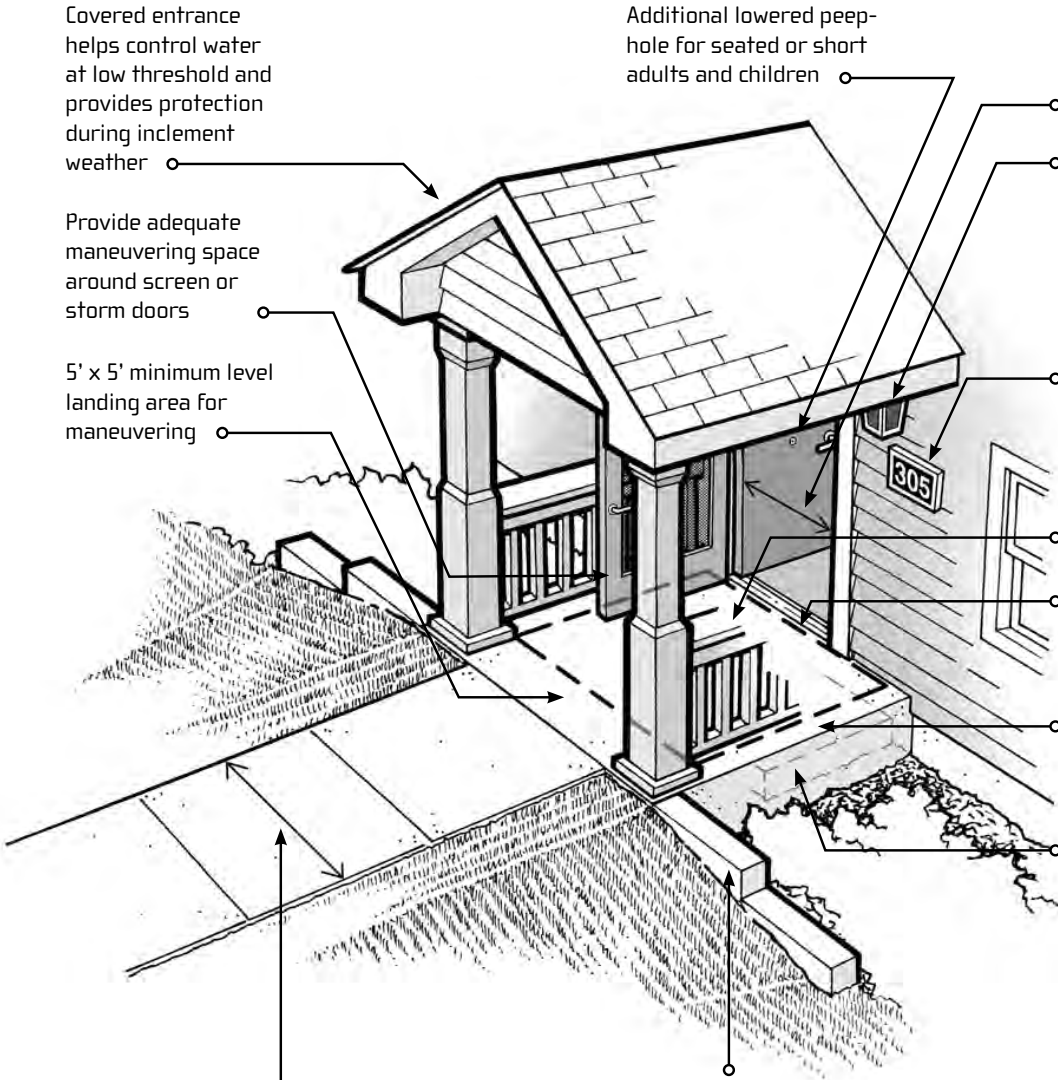
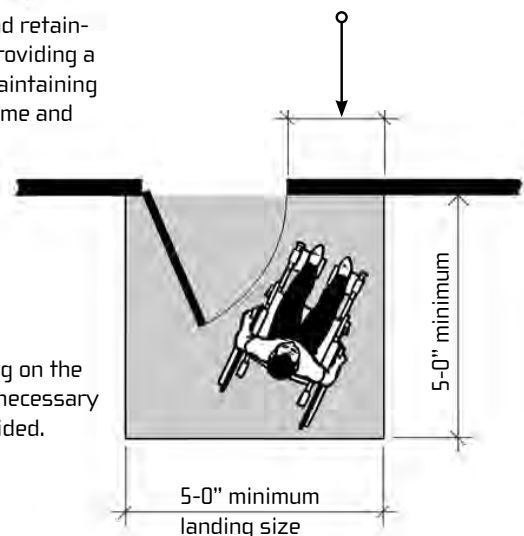



Stepless entries paving styles.

Functional & decorative entries with gradual inclines.



After

Gradual incline replaces entry steps.  
Open turning area & easy care landscape.



Before